

Electronic-Scale V6 – Operating instructions



Table of contents

<i>Preparation</i>	2
<i>Measuring</i>	2
<i>Using the scaleplate</i>	2
<i>Checking parallax (A)</i>	2
<i>Using the fine-adjustment</i>	2
<i>Using the center line (B)</i>	3
<i>Using the special markings (C)</i>	3
<i>Using the symmetric image balance (D)</i>	3
<i>Checking period</i>	3
<i>Pre-conditions for precise measurements</i>	3
<i>Maintenance</i>	3
<i>Trouble shooting guide</i>	3
<i>Changing the battery</i>	4
<i>Microscope</i>	4
<i>Mounting the microscope [42]:</i>	4
<i>Storage instructions</i>	4
<i>Using the electronics</i>	5
<i>Designation of parts</i>	5
<i>Possible error messages and their resolution</i>	6
<i>Applying „Enavit n“</i>	6

Electronic-Scale – Operating instructions

Preparation

Lay test object on a flat surface. Place the Electronic Scale on top of the product, adjust it parallel to the marks with the help of the positioning slides [18], loosen the locking screw [15] (Photo 2).

If high precision is required, adjust the parallelity using the crosshairs of the scale plate.

Measuring

Align to first mark (look through the lens, move the carriage [23] until the scale marks correspond), reset the display, align to 2nd mark, read value from display.

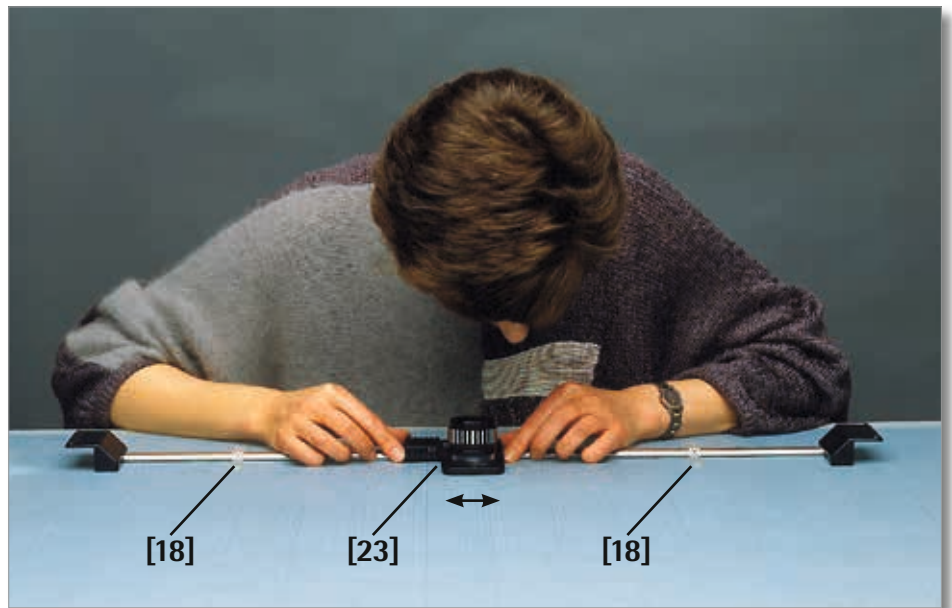

A

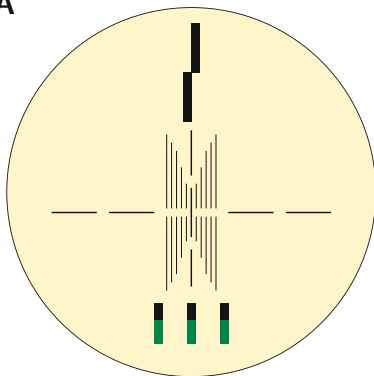

correct

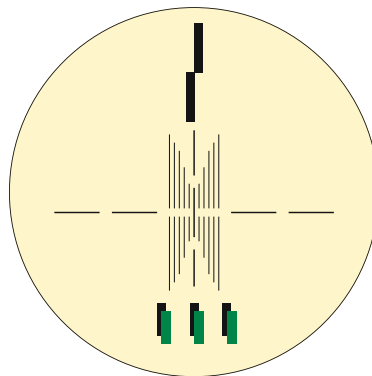

wrong

Using the scaleplate

The arrangement of lens markings offers a variety of possibilities:

Checking parallax (A)

Parallax indicators will tell you whether you are looking straight into the lens. This may be important if you are measuring off contact.

Using the fine-adjustment

1 Preparation: Coarse alignment (move the carriage by hand), the green tape of the fine-adjustment nut [13] has to be centered (approx. 1.5 mm have to be visible);

2 Tighten the locking screw [15] of the clamp slide;

3 Fine alignment by turning of the fine-adjustment nut [13].

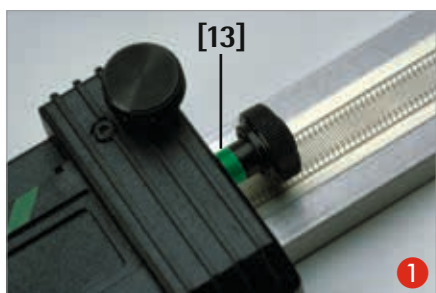

Using the center line (B)

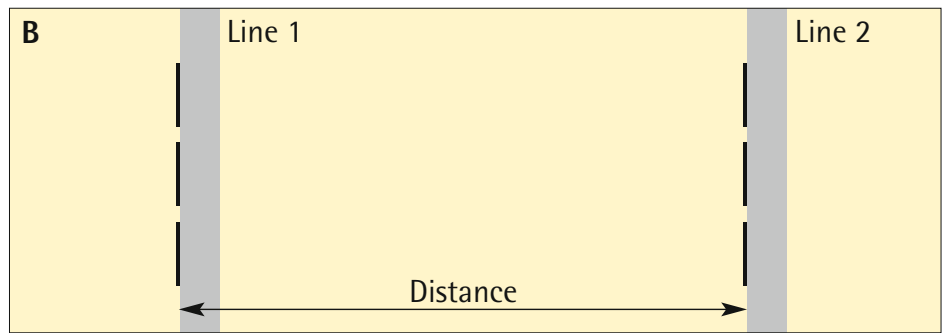

Using the special markings (C)

Special markings are provided to check the thickness of lines by aligning either line edge to the upper and lower brim of the special markings.

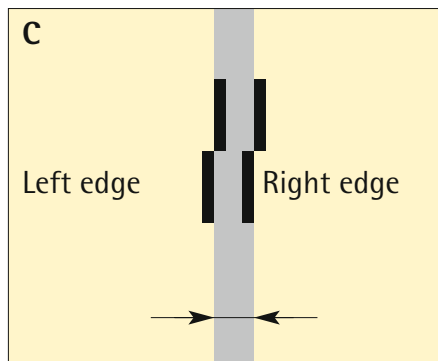

Using the symmetric image balance (D)

Symmetrical balanced images measure the distance between lines up to 1 mm wide by visually centering the line containing a symmetric image.

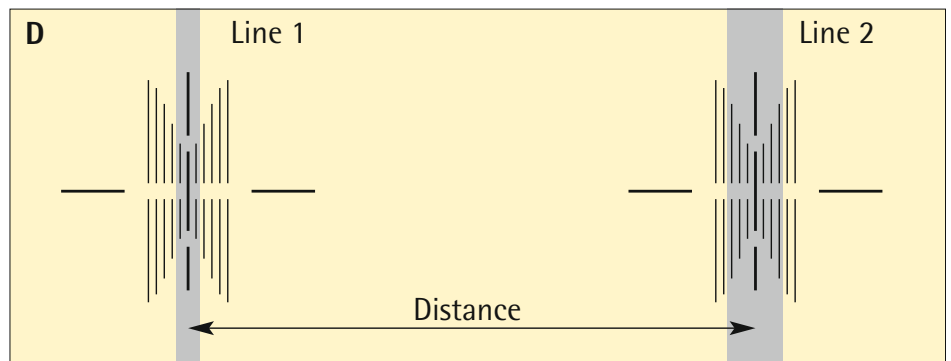

Checking period

It is recommended to check the accuracy of the device regularly, e.g.: once a year.

Pre-conditions for precise measurements

- flat surface
- the object should be accommodated to the ambient temperature and humidity and stabilized in this environment sufficiently
- stable conditions (ideal = 20°C)
Attention:
 - radiant heat of illuminations
 - body temperature of the person using the scale
- take into consideration the accuracy of the measuring instrument, the deviation of single measurements and the coefficients of expansion of different materials

Maintenance

Precautions

- Do not expose to any electrical fields or voltages
- Do not damage the scale surface
- Protect from cold, heat and moisture
- Avoid contact to fluids
- Use only «ENAVIT-N» for cleaning
- For installing the scale into a device, contact your dealer

Trouble shooting guide

How to take care if...

- ...the carriage does not run smoothly or
- ...«impossible» values are displayed?

Clean the guide rail [24] with petroleum ether and cloth along its entire length. Then spray some ENAVIT-N care spray on to another cloth* and use it to distribute the care spray over the surface of the bar *(clean and lint-free)

The protective film created in this way prevents moisture (e.g. from sweaty hands or breathing) from disturbing the electronics.

Changing the battery

- 4 Remove the locking screw [15]
- 5 Remove the screws (3 pcs.)

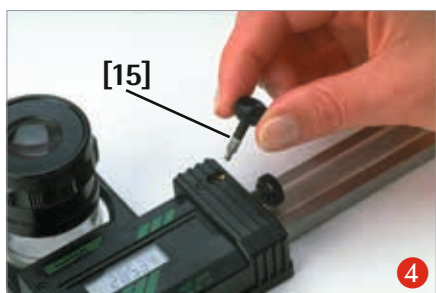

- 6 Remove the casing [17], remove the protective insert [9]
- 7 Remove the battery



- 8 Insert new battery («+»-pole looking upwards)

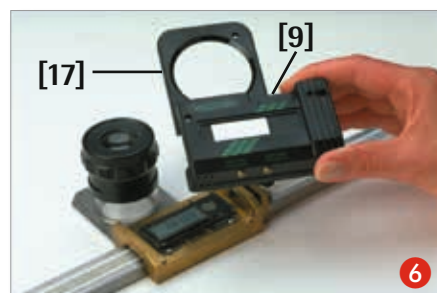

Microscope

- 10 Cleaning the scale plate of the microscope (with cotton)

Mounting the microscope

[42]:

- 11 type «ESM»: using the stand [43]
- 12 13 type «ES»: using the adapter [41]



Storage instructions

Unpacking / packing:

Please retain the box and all transport cushioning (pieces of foam) for return (repair / calibration).

Storage / transport:

When not in use, and for transportation, place the Electronic Scale into the case as follows: Slide positioning slider [18] outwards to the handles, turn magnifying glass [8] downwards to its lowest

possible height, move measuring carriage [23] completely to the left to the field provided for this purpose, and fix with clamping screw [15].

Specifications:

Resolution: 0.01 mm/0.0005"

Repeat accuracy: 0.01 mm

Error range

up to 500 mm	= 0.03 mm
up to 800 mm	= 0.04 mm
up to 1000 mm	= 0.05 mm
up to 1300 mm	= 0.08 mm
up to 1500 mm	= 0.10 mm

[Back to table of contents](#)

Measurement units: metrical (mm)
and british (inch)

Power supply:

1 lithium battery 3V,

type CR2032, capacity 190 mAh

Battery life: approx. 4000 h

Operating temperature: +10°C
to +40°C

Data output: RS232 compatible

Guarantee: 1 year

All rights reserved!

Using the electronics

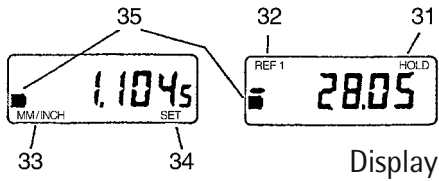

• Turn ON

Press button [1]. The electronics will be in the same mode as prior to turning it off

• Changing the mode

Press button [2] until the indicators change [32] ↔ [33] (>2 sec./possible only when «HOLD» [31] is not displayed)

Mode 1:

display = MM/INCH [33]

Mode 2:

display = REF 1 [32]

• Resetting (reset the display)

in mode 1 only:

press button [1]

• Changing the unit (mm/inch)

in mode 1 only:

press button [2]

• Memorizing (holding) a value

in mode 2 only, no peripheral units may be connected:

press button [1], «HOLD» [31] will be displayed, the value will be stored until the memory is cleared

• Clear the memory

in mode 2 only:

press button [1], «HOLD» [31] will disappear and the current value will be displayed

• Send data

in mode 2 only:

1. Preparation:
start peripheral unit, remove the protective insert [9], insert the opto-cable.

2. Send data

press button [1]

• Turn OFF

press button [1] (>2 sec.)

10. Battery

11. Spring

12. Clamp slide

13. Fine adjustment nut

14. Ball

15. Locking screw

16. Plate: serial number

17. Casing

18. Positioning slide

19. Left handle

20. Right handle

21. Wiper for capacity strip

22. Reset opening

23. Measuring carriage

24. Guide rail

25. Ball bearing

26. Wiper for ball bearing

Display:

31. Indicator:

memory function «HOLD»

32. Indicator:

Mode 2 «REF 1»

33. Indicator:

function of button [2]

34. Indicator:

function of button [1]

35. Indicator:

end of battery life

Accessories:

41. Adapter

42. Microscopes 25x or 50x

43. Stand for microscope

Designation of parts

1. Button [1]:

ON/OFF, reset, hold/send data

2. Button [2]:

mm/inch toggle, mode selection

3. Display (LCD)

4. Support

5. Roller

6. Scale plate (standard or PCB)

7. Acrylic glass ring

8. Lens 10x

9. RS-232 data output,

protective insert

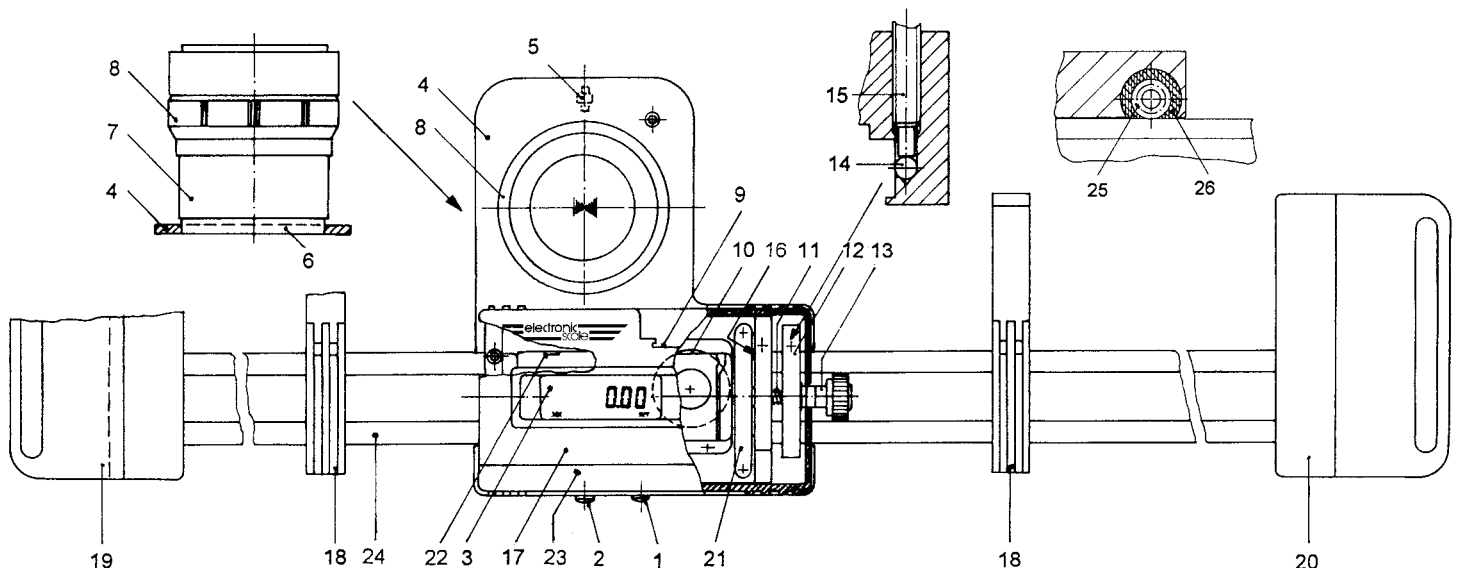

Possible error messages and their resolution

When the Electronic Scale is used for a long time, one of the following error messages may appear on the display:

ERR 0 = Sensor error
e.g. moisture on the scale, under the electronics
or false relative position of the electronics to the capacitive band

ERR 3 = Data overflow
is either triggered by a voltage error, e.g. brief current surge with electronics switched off
– static discharge
or by a count that was triggered but not stopped, e.g. if a contact to the capacitive band was missing – if for example the car is driven out over the end of the scale with the electronics switched off

Remedy = Wipe off bar and/or reset the electronics by removing and reinserting the battery.
If this does not help, send Electronic Scale to be repaired

Applying „Enavit n“

- To prevent damages please avoid the ELECTRONIC SCALE being exposed to any hostile environment!
- For maintenance it does not need a lot of the preservative-spray ENAVIT N, do not apply too much of it at once! Best is to simply spray the liquid onto a rag by pressing the head of the bottle once or twice (not more!). Then apply and distribute the preservative-liquid by moving the rag over the steel rod without pressure.
- Do not put the used cloth into the wooden storage case!